

NWF299-5

ELECTRIC OBSTETRIC BED



NWF299-5

FEATURES AND HIGHLIGHTS

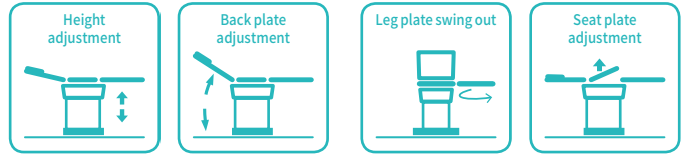

Technical parameters

▪ External (LxW):	1950x660mm
▪ Table height:	680-940mm
▪ Seat plate up folding:	0-20°
▪ Seat plate down folding:	0-9°
▪ Back plate up folding:	0-45°
▪ Back plate down folding:	0-10°
▪ Leg plate abduction:	0-90°
▪ Load bearing:	≤300kg



Technical configuration

<input checked="" type="checkbox"/> Arm support	2 pcs
<input checked="" type="checkbox"/> Handle	2 pcs
<input checked="" type="checkbox"/> Leg support	2 pcs
<input checked="" type="checkbox"/> Stirrup	2 pcs
<input checked="" type="checkbox"/> Slider	4 pcs
<input checked="" type="checkbox"/> Tightener	2 pcs
<input checked="" type="checkbox"/> Hand controller	1 pc
<input checked="" type="checkbox"/> Foot switch	1 pc
<input checked="" type="checkbox"/> Stainless steel basin	1 pc



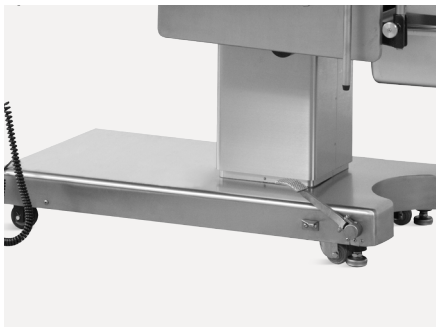

Material

The chassis cover is made of high quality 304 stainless steel, which is welded by the robot seamlessly. The shape is beautiful and stable.



Mattress

Polyurethane foam mattress, waterproof and seamless, easy cleaning and disinfection.

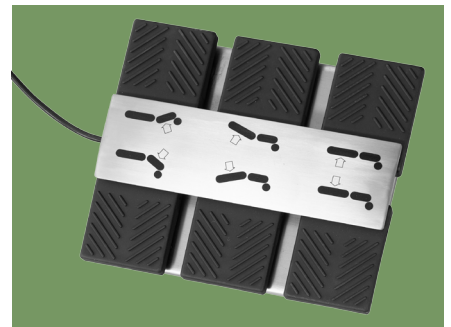

Foot pedal controller

All the functions are controlled by hand controller and foot switch.



Braking system

The pedal controls the brake function of the casters.



Control System

Electric control the height lifting, seat plate up and down, back plate up and down, convenient operations.



Arm Support

The arm support could be adjusted into multiple angles with the straps, it can be used to comfortably fix the puerpera's arm at various angles.



Leg supports

The leg support is integrated with stirrup function, and the delivery bed is equipped with a pair of stirrups.



Auxiliary Table

The auxiliary table can be folded 90° outwards, used as a instrument table, detachable, and adapt to a variety of surgical environments.



Pull handles

Pull handles can be folded to horizontal position. Easy patient mobilisation.



Sewage basin

Equipped with stainless steel sewage basin and other various accessories.



NUMBER WIN

MEDICAL TECHNOLOGY

As the circumstance of printing, the photos might have minor difference on color, tactile from real products.
As the update of design and improvement, parameters and outlook of products might change, thanks for understanding.



7x24

Online 24 Hours for Sales Service
Timely Response for Clients' Problems

+86 18021239272

Suzhou Number Win Medical Technology Co.,Ltd.

No. 35, Lehong Road · Zhangjiagang (Jiangsu) · China

export@number-win.com

www.number-win.com



Company video



General catalogue